

**PANTOKRATOR**  
*A better way*

# GRID2.0

Decentralised solutions for the Energy Transition

Webinar

20 May 2026



# PANTOKRATOR

*A better way*

Pantokrator is a leading advisory firm based in London focused on helping climate tech companies raise capital to scale to provide a better way



**Andre Shortell**  
Managing Partner, Co-Founder

[andre.shortell@pantokratorltd.com](mailto:andre.shortell@pantokratorltd.com)



**Alex Moody, CFA**  
Vice President

[alex.moody@pantokratorltd.com](mailto:alex.moody@pantokratorltd.com)

# Previous Grid Themes & Webinars

February 2025



October 2025



May 2026



## Build more, faster

Modular & digital solutions to accelerate expansion

## Squeeze more

Power flow optimisation & grid enhancement

## Resilience

Balancing, maintenance & monitoring

## Decentralised solutions

Microgrids, data centres & onsite power

## Energy demand accelerating ~3x ...



## ... yet grid is highly under-utilised

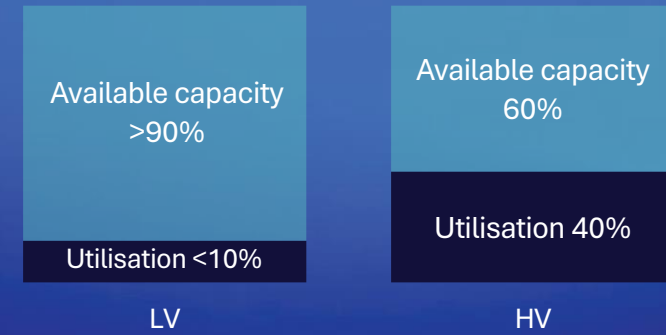

## Distributed solutions scaling to meet local needs

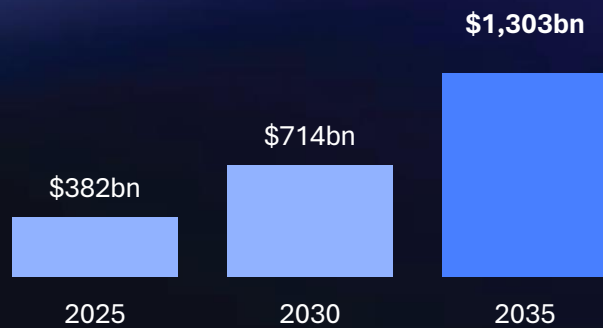

**\$800m+**

Venture investment<sup>1</sup>

# What is a decentralised grid?

Electricity network using local DERs to generate and store energy close to point of use

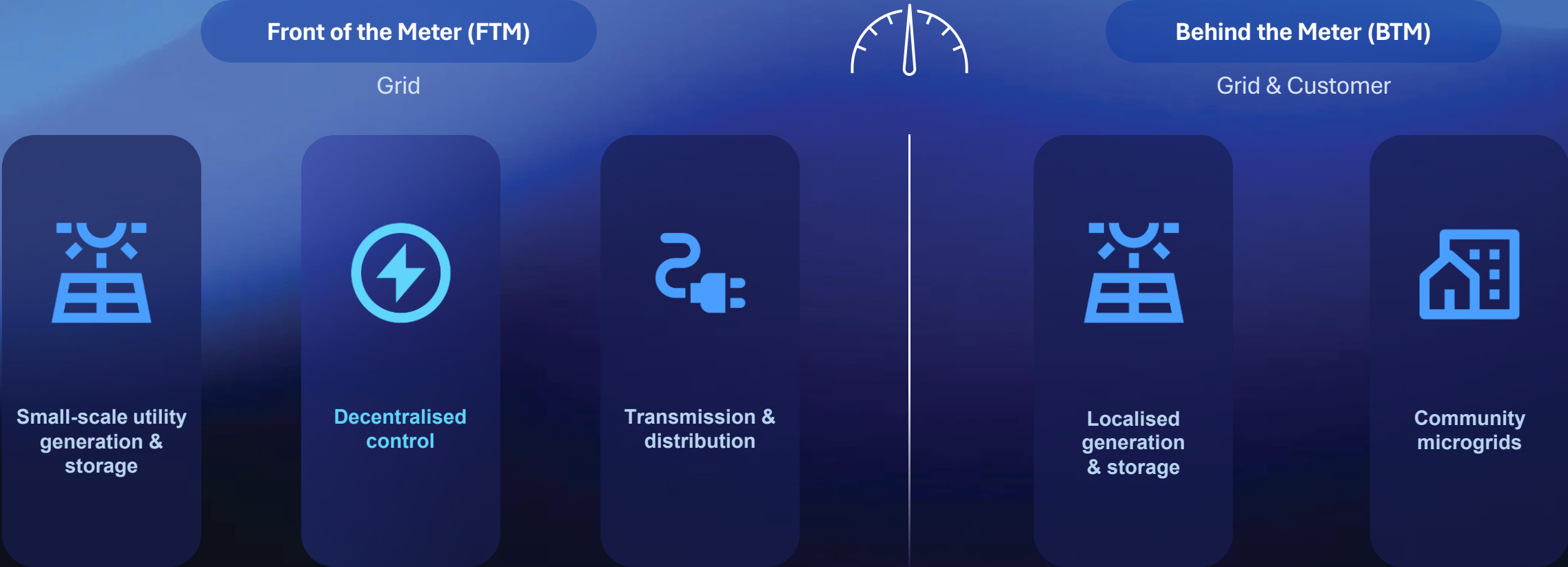

# Storage growing >4x to meet demand

Decentralised energy storage market, \$bn

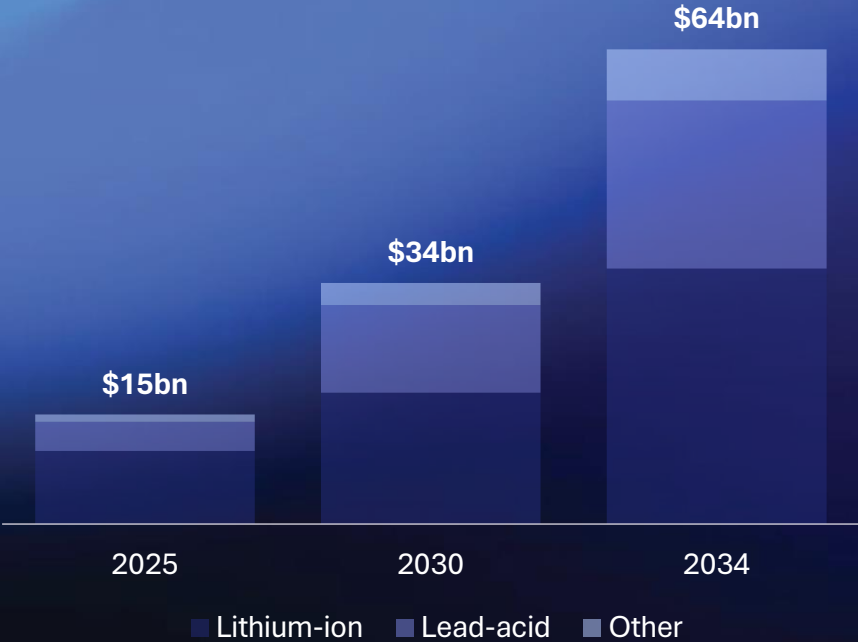

Decentralised energy storage systems by capacity, %

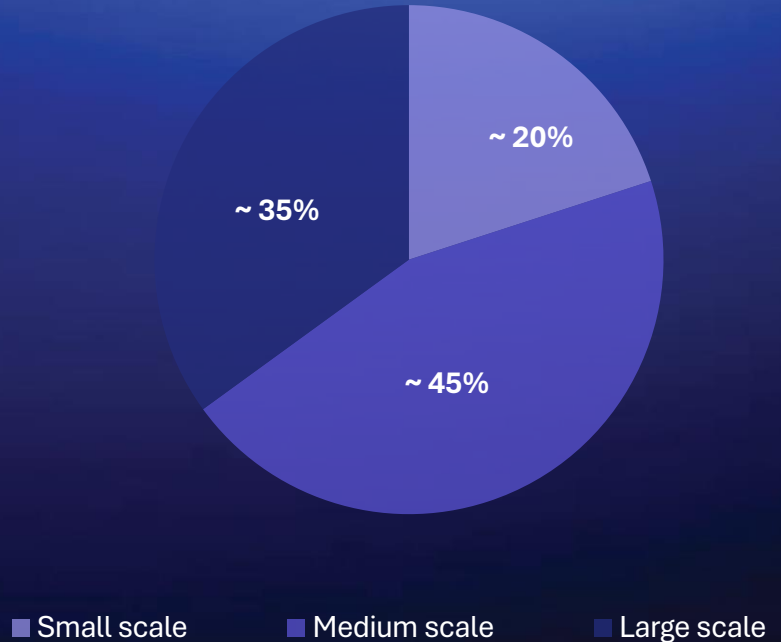

# Data centres rapidly growing, grid unable to keep up

Data centre consumption, (TWh)

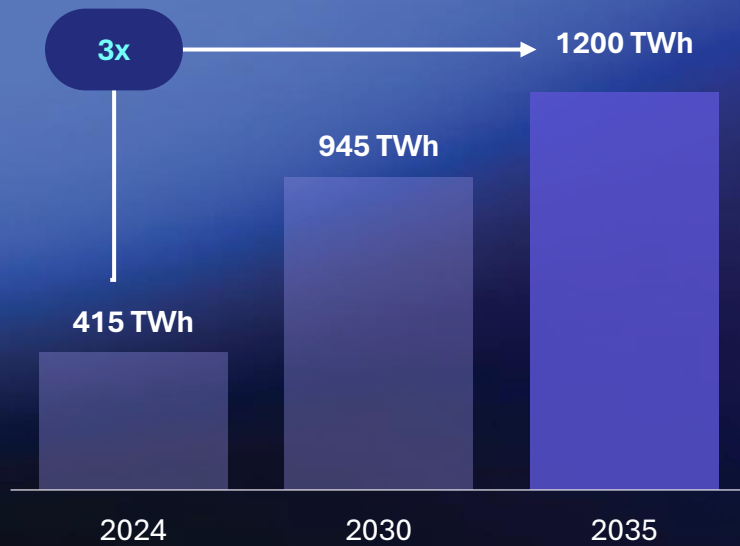

Average grid connection queue, (years)



# Small cost to “bring-your-own power”

## 100 MW data centre CAPEX

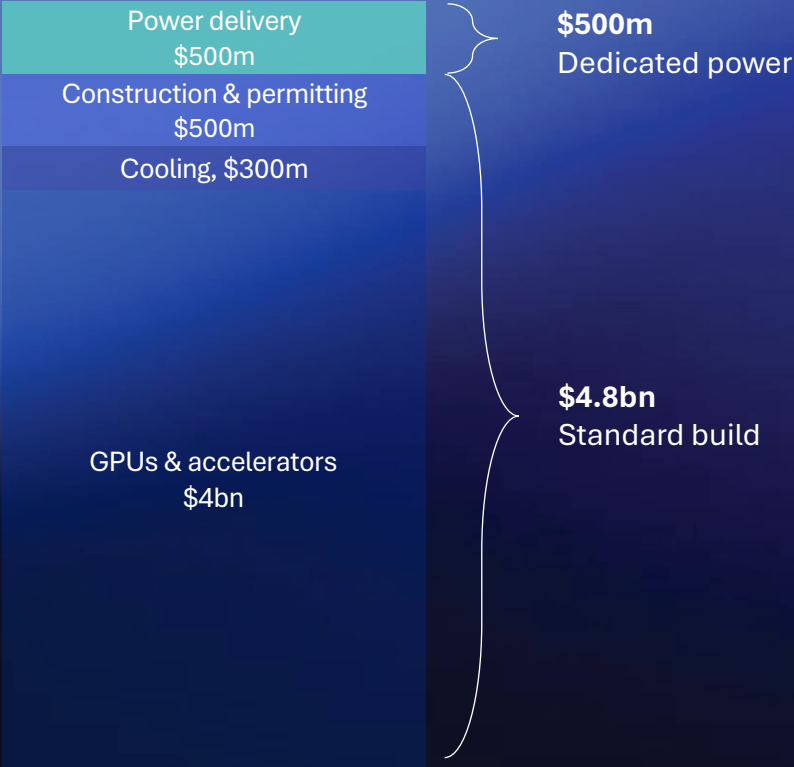

## Data centres sourcing own ecosystems

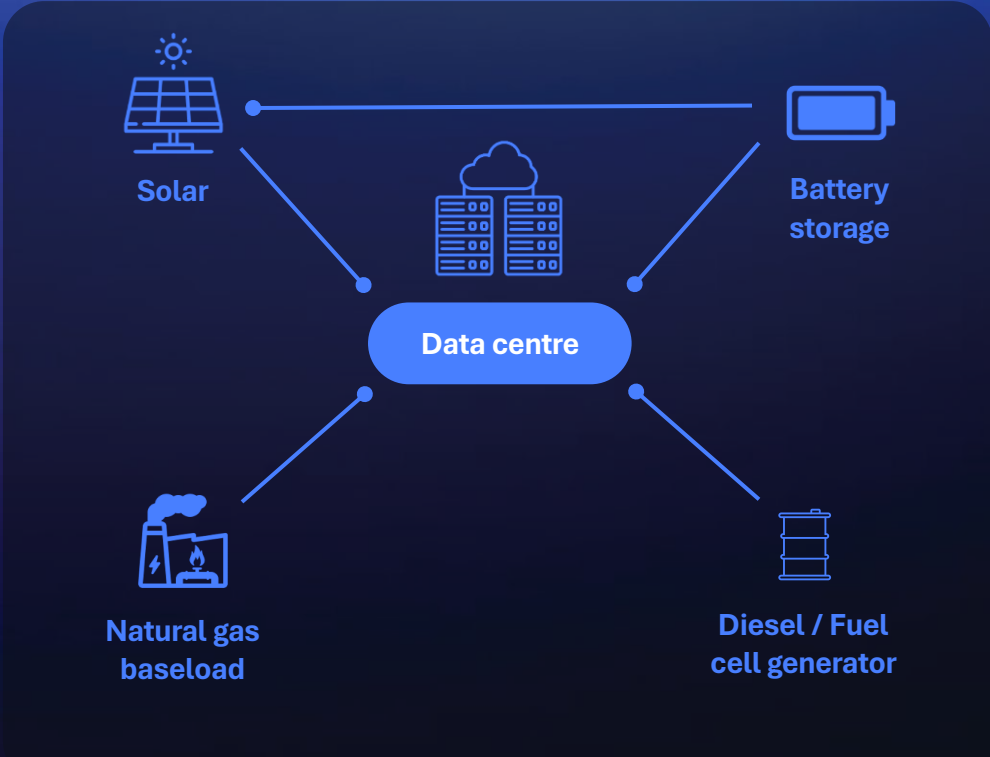

# Decentralisation enables a dynamic grid

## Traditional grid

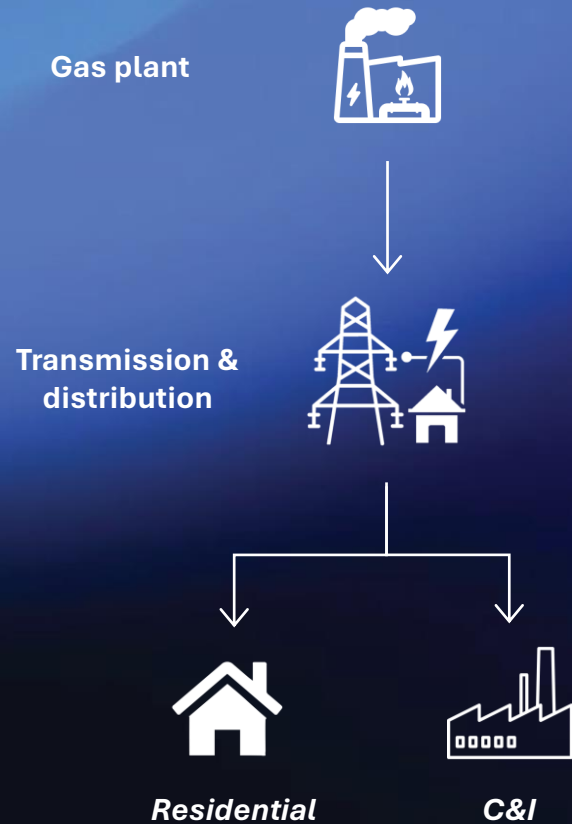

↓ one direction only

## Modern dynamic grid

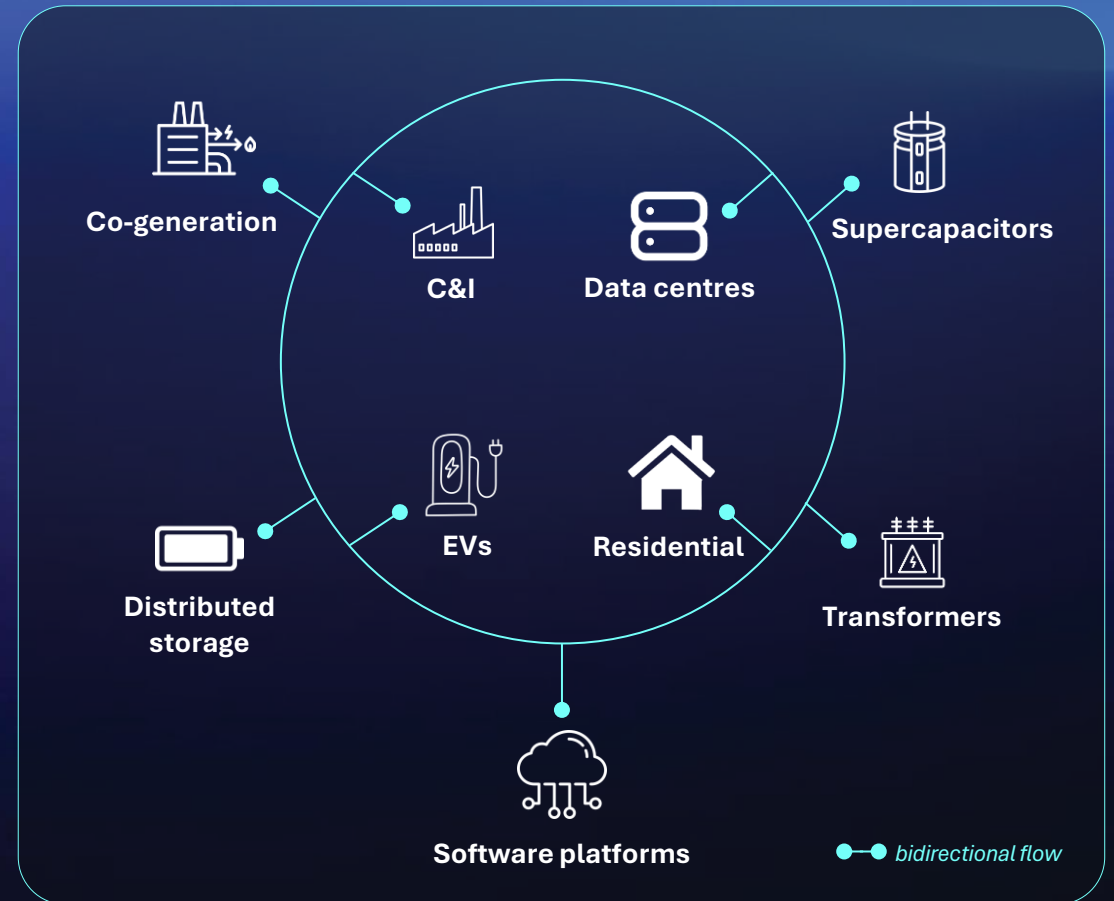

# Select players in the decentralised ecosystem

## Co-generation

ENCHANTED ROCK

Canopy Power

Floral Energy

SCALE MICROGRIDS

VoltaGrid

## Distributed storage

Haven

nyobolt

sparkfund

TETHER

uplight

## Enabling infrastructure

BLIXT

ConnectDER

nuventura

SKELE+ON TECHNOLOGIES

VEIR

## Smart transformers

AMPERESAND

OG MATRIX

HERON

Hyperscale Power

IONATE

# Growing interest from investors

\$800m+ notable deals since H2 2023



# Outlook

## Power in the top slot

Energy limiting superintelligence, ability to shorten build-out = high value

## Overbuilt but underutilised grid

Improving utilisation from existing assets = cheap power

## Hyperscalers being proactive

Incentivised and have resources to push transition

## T&D critically overlooked

Strong on generation, need more innovation around control

## FTM vs BTM blurring

End-users being forced to think like utilities, partnering to fill gaps

## De-risking supply chain

Trusted suppliers at capacity, pioneers scaling to meet demand

# Expert panel



**Haroon Inam**  
*CEO*



**Matthew Williams**  
*Founder & CEO*



**Julien Zingel**  
*Sales Director*



**Pier LaFarge**  
*CEO*



# Winning the AI Infrastructure Race Globally

# DG Matrix – Delivering GW-Scale Infrastructure Solutions

**10 GW**

Production capacity online in 2027

Deployments live since

**2024**

**320+**

engineers

(largest SST team in the world)

## Clients, Partners, and Investors



And other global partners

# <sup>15</sup> DG Matrix is the fast, flexible, resilient power fabric for *any* datacenter architecture

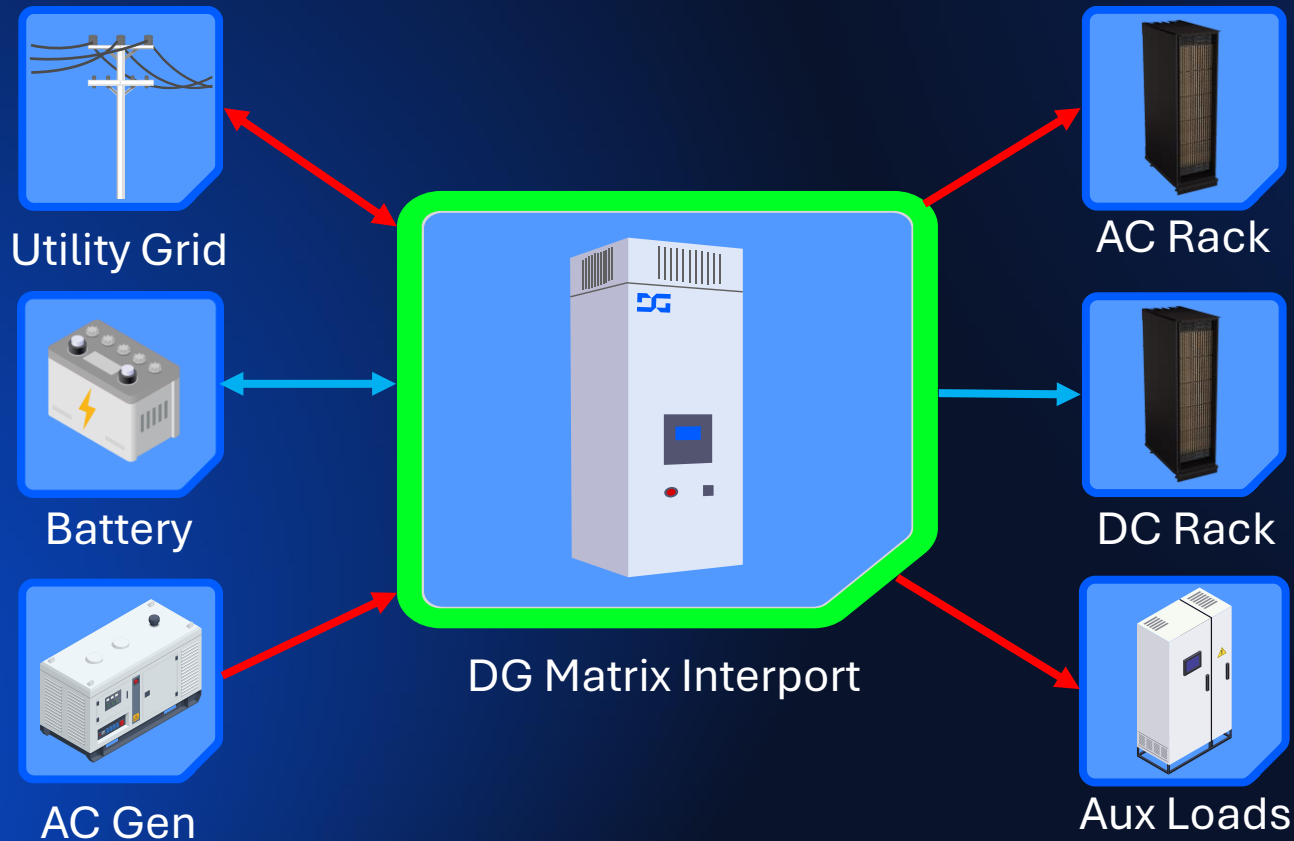

## Faster Time to Market

- Simplified supply chain and deployment

## Future-proofing

- Software-programmable for any datacenter architecture, AC or DC

## Greater Resiliency

- Redundant design with fewer failure points and galvanic isolation

## Lower Total Cost of Ownership

- Built-in EMS for LCOE optimization and dynamic load management

# DG Matrix Simplifies Any Datacenter Architecture

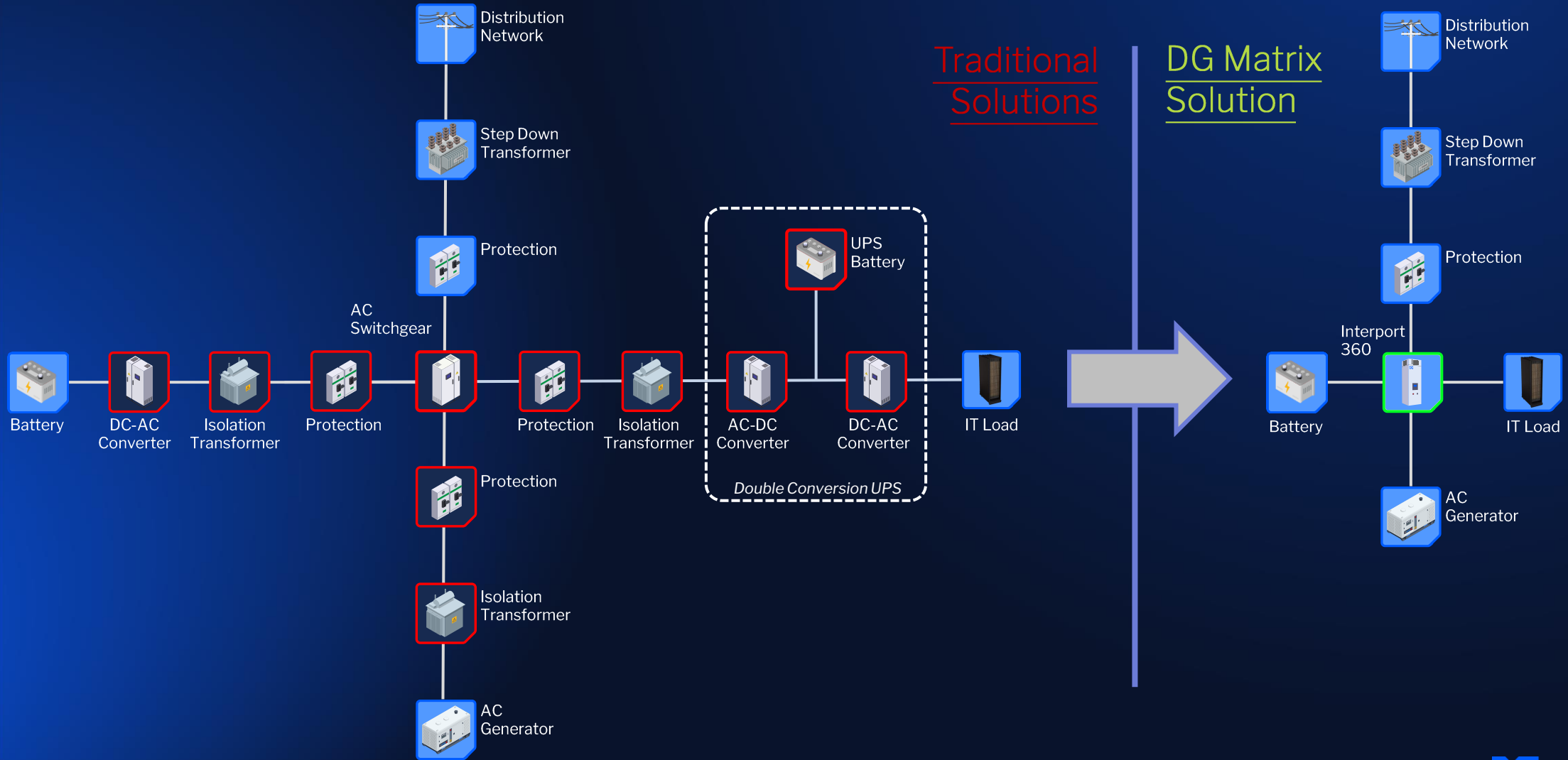

DG Matrix at density will replace two 4 ft x 30 ft skids with a fraction of one skid

# Two Entire Skids Consolidated to a Box

Half of today's  
infrastructure  
needs



One unit on legacy  
tech skid is 3x  
footprint of  
DG Matrix Interport™



The DG Matrix Multi-Port  
Solid-State Transformer



# 19 Interport 360 Flex Series at MW Scale



Example: 3.2 MW Skid (2.8 MW with N+1)



Interport Flex 8x400-kW

AC/DC Switchboards, Control Cabinet, and Auxiliary

Category	3.2 MVA Flex Series	Custom MVA Flex Series
Power Range	2 - 3.2 MVA	1 - 10 MVA
AC Port Range DC Port Range	400 - 480 300 - 920	400 - 480 300 - 1500
Native Port #	6	6
Embedded EMS & Grid Services Capability	✓	✓

## Port Configuration (example):

- Port 1 - AC - Grid
- Port 2 - AC - AC Genset
- Port 3 - AC - IT Load
- Port 4 - DC - Battery (UPS functionality)
- Port 5 - DC - Future IT Load
- Port 6 - DC (Fuel Cell, Auxiliary Load, etc..)

Key Note: Enclosure is only needed for outdoor installations

# Build AI Capacity at the Speed the Market Demands

Interport turns power from your biggest constraint into your competitive advantage.

Haroon Inam  
Co-Founder & Chief Executive Officer

+1 (724)-877-7773

[haroon.inam@dgmatrix.com](mailto:haroon.inam@dgmatrix.com)

[www.dgmatrix.com](http://www.dgmatrix.com)



Transforming power – Hardware-software backbone for smart grids and data centers.

# HW-SW coupling will be key.

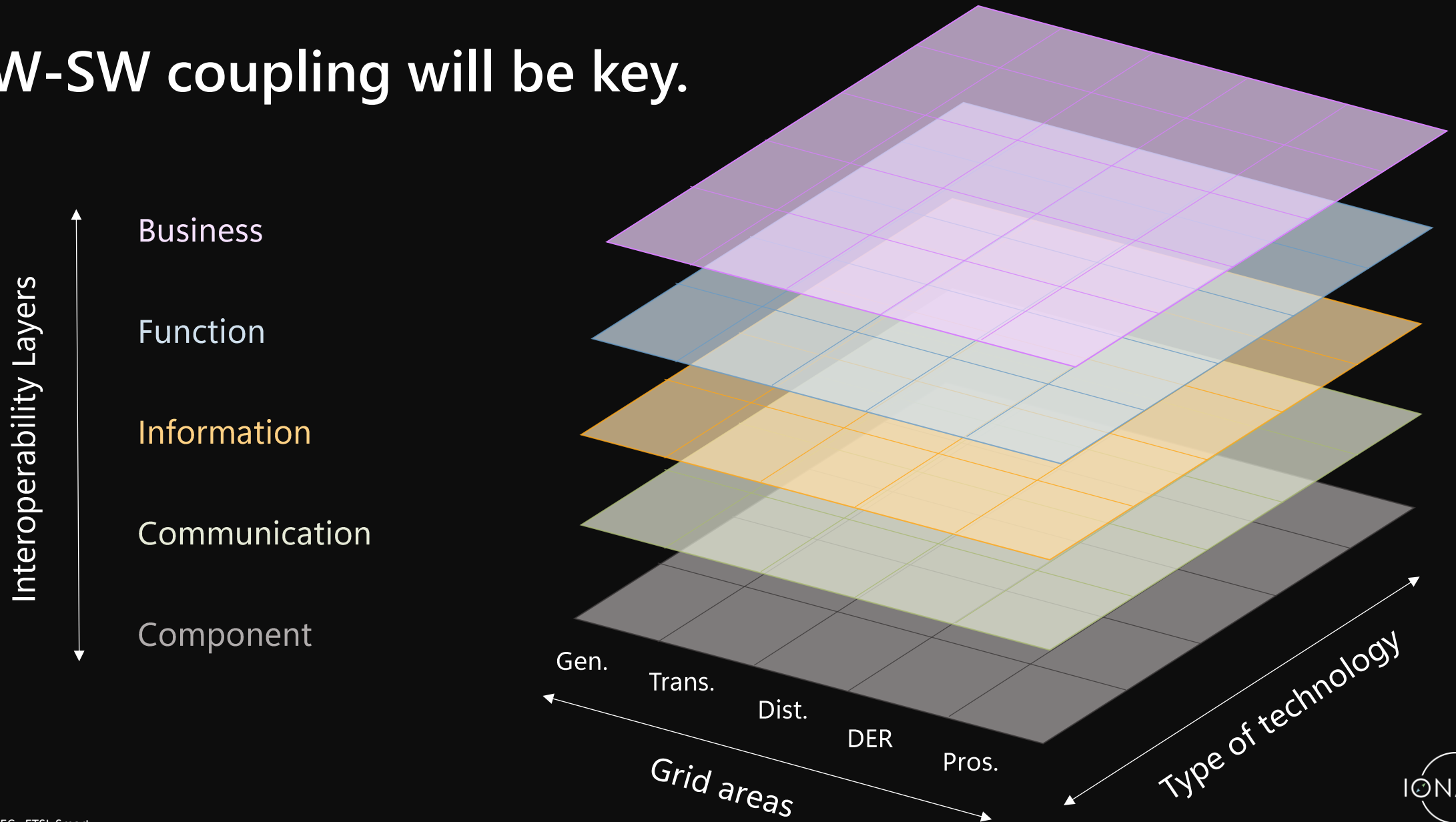

# At IONATE, we designed a new building block.

The Hybrid Intelligent Transformer (HIT): all-in-one device for smart power conditioning

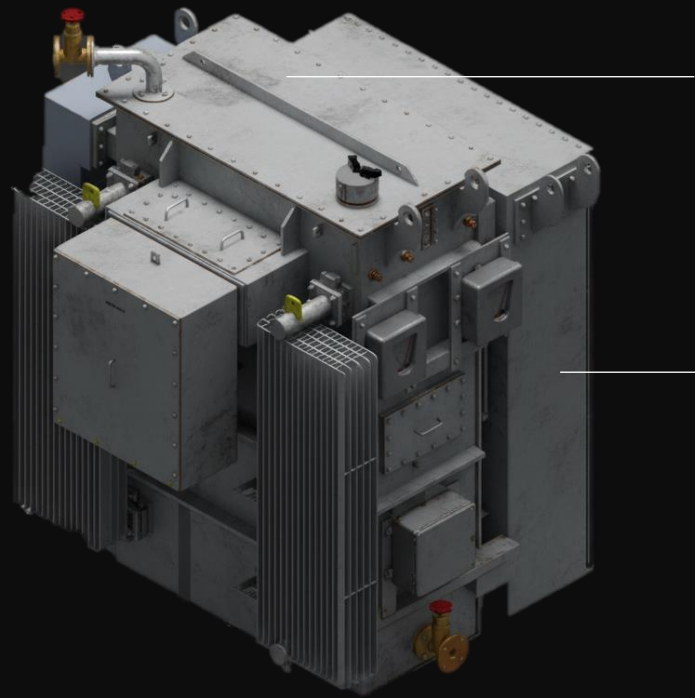

## Modified transformer core

Control: magnetic windings

## IONATE brain

Electronics + bypass: system uptime

## Real-time data + Dynamic control

voltage, harmonics, reactive power

# The HIT unlocks value across the energy transition.



Real-time power quality control & visibility at better CAPEX and OPEX vs. alternatives.

# Aurora intelligently orchestrates the HIT's edge control.



# Our vision: systems that optimise themselves.

We're building Aurora's AI coordination algorithm in partnership with the University of Oxford.

Current orchestration solutions are limited in their reaction time in minutes.

IONATE's HW-SW coupling will be able to **optimise any network in real-time.**



33%

More DERs

25%

More system capacity

6%

Reduction in losses





Get in touch  [matthew@ionate.energy](mailto:matthew@ionate.energy)



skeleton+

# Mission-Critical Power for Grid Application

Certified



9001:2015



14001:2015



IATF 16949

# Becoming the Skeleton of Every Energy System

Focused on short-duration applications, where Li-ion batteries fail



**15+ years** of deep **R&D** in our own materials, production processes, and market-leading products, secured by **70 patent families**



**~300 people worldwide**, including the largest R&D and engineering team in the high-power industry globally.



**€330m** raised since the founding of the company in 2009



**€95bn** addressable market opportunity for short-duration, high-power energy storage



Manufacturing in Germany and Finland, Development in Estonia, R&D laboratory in France

## Selected existing investors

Owners of

Marubeni    Inno    CAF

Co-founders of:

SIEMENS    CBMM    adyen

# Only Company To Have Full Value Chain From Materials To Software

**skeleton+**

Resulting in higher quality, reliability, and smaller product for high-power needs



## Award winning core technology protected through 70 patent families



>110 patents granted or pending

Unique advantage with **Curved Graphene**, Skeleton's patented carbon raw material

### FULL CONTROL OVER THE ENTIRE VALUE CHAIN



Raw Material  
Curved Graphene™



Single Cells  
Supercapacitors™



Modules & Power Electronics  
From low to high voltage needs



Software & Systems  
MWs of immediate power

# Technological Advantage Through Superior Carbon Raw Material

skeleton<sup>+</sup>

Backed by the largest R&D team in the industry



- + **High power density** (up to 60 kW/kg)
- + Limited energy density (up to 16 Wh/kg)
- + Extreme cycle life (>1 million)
- + Extremely fast charge rate (2000 C)
- + High inherent safety
- + No rare metals



- + High power density (4 kW/kg)
- + **Increased energy density** (65 Wh/kg)
- + Long cycle life (50,000)
- + Fast charge (<60s)
- + Extreme power (20 C continuous, 100C peak)
- + High inherent safety
- + High recyclability and sustainability
- + No Graphite, no Co, <5% Li



- + Limited power density (0.5 kW/kg)
- + **High energy density** (250 Wh/kg)
- + Limited cycle life (<6000)
- + Slow charge rate (3 C)
- + Safety concerns
- + Utilizes critical raw materials (Li, Graphite, Co)

# INERTIA – Critical for Secure and Resilient Power System Operation

The Perfect Storm: Increased Risk of Blackouts due to Loss of Power System Inertia



Traditional, **synchronous generator-dominated** power systems have **high inertia** and are **capable of regulating grid voltage and frequency**.



The growing share of grid-following **inverter-connected renewable generation** and **industrial drives** reduces the **inertia and short-circuit capacity** available in the grid.



**Hyper growth** in power demand due major **AI data centers** builds across the continent



**Low inertia leads to** unforeseen frequency and voltage instability, creating **grid and frequency disturbances**, increases **susceptibility to blackouts**.

# The Perfect Storm: Renewables in the GW Range & Building AI Data Centers

**skeleton+**

Solution required to master high power demand

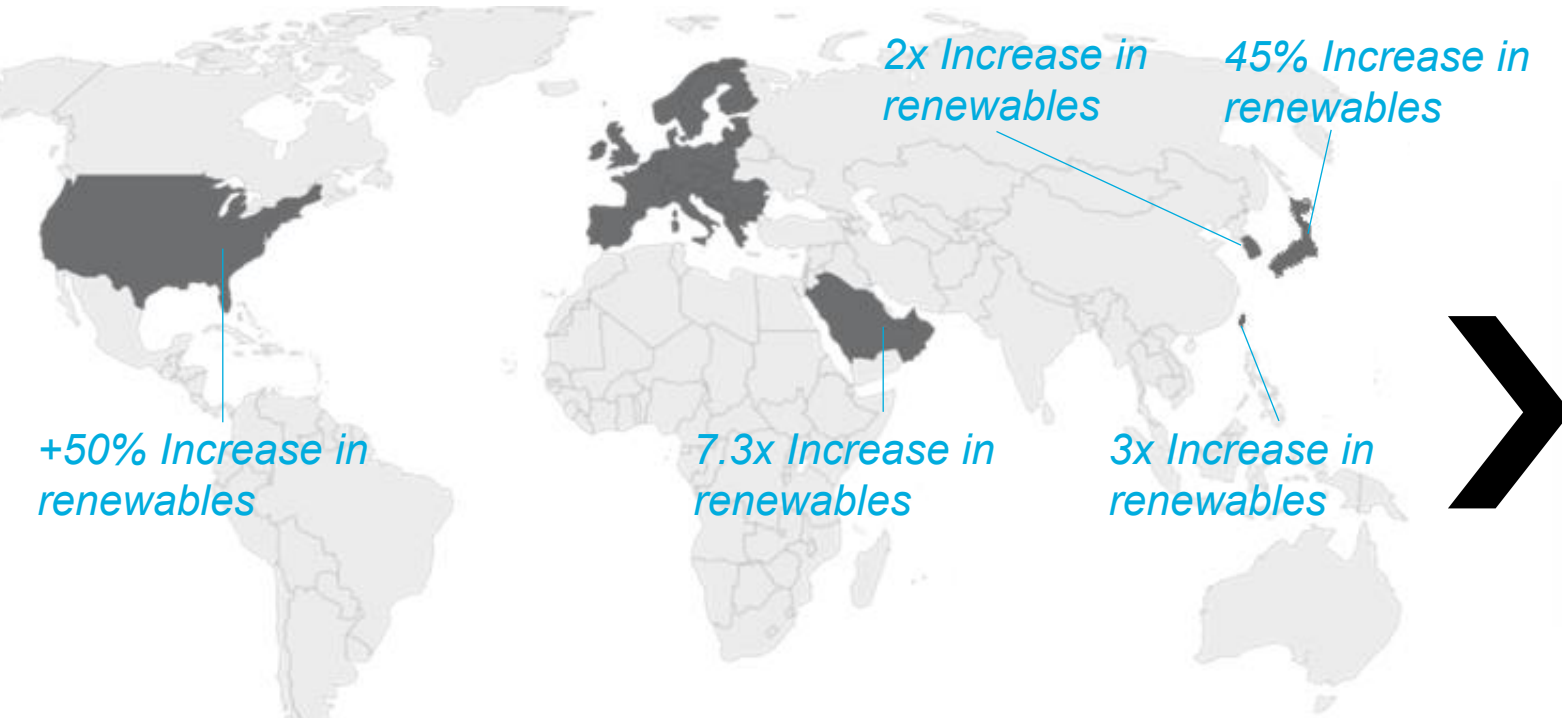

**E-STATCOM**

**GrapheneGPU**



Major **growth in renewables** power generation in the grid  
**Data center** power demand will **triple** by 2030

Without upgrading to enhanced technologies the **risk for blackouts** increases

High power **grid stability** & **data center** solutions reducing risk of blackouts.

To address fluctuations in AI data centres, the solution is not at grid-level but with our **GrapheneGPU**

sparkfund

# Delivering the Distributed Grid



# sparkfund

## Delivering the Distributed Grid

We are a utility services company unlocking capacity on the grid. Through our Distributed Capacity Procurement (DCP) model, we enable utilities, energy majors, and large-load customers to deploy front-of-the-meter assets as distribution infrastructure.

With over a decade of experience, our battery and gensets deployment services support program design, grid value assessments, asset host engagement, and procurement manage to ensure on-time, on-budget to maximize system value and lowest cost.



## CUSTOMERS



# What is Distributed Capacity Procurement?

# Utility-grade Capacity from Distributed Assets

## DCP: A New Utility Resource Class

**Approach:** Sparkfund deploys distributed batteries through the utility.

**Assets:** 1-3 MW front-of-the-meter (FTM) batteries and/or gensets deployed on distribution system.

**Scale:** Aggregated program delivery of 200-500 MW of reliable, utility-grade power.

**Function:** Control-room visible (SCADA) and transmission-accredited assets that clear headroom.

**Resource:** Unlocked capacity on the utility distribution system.

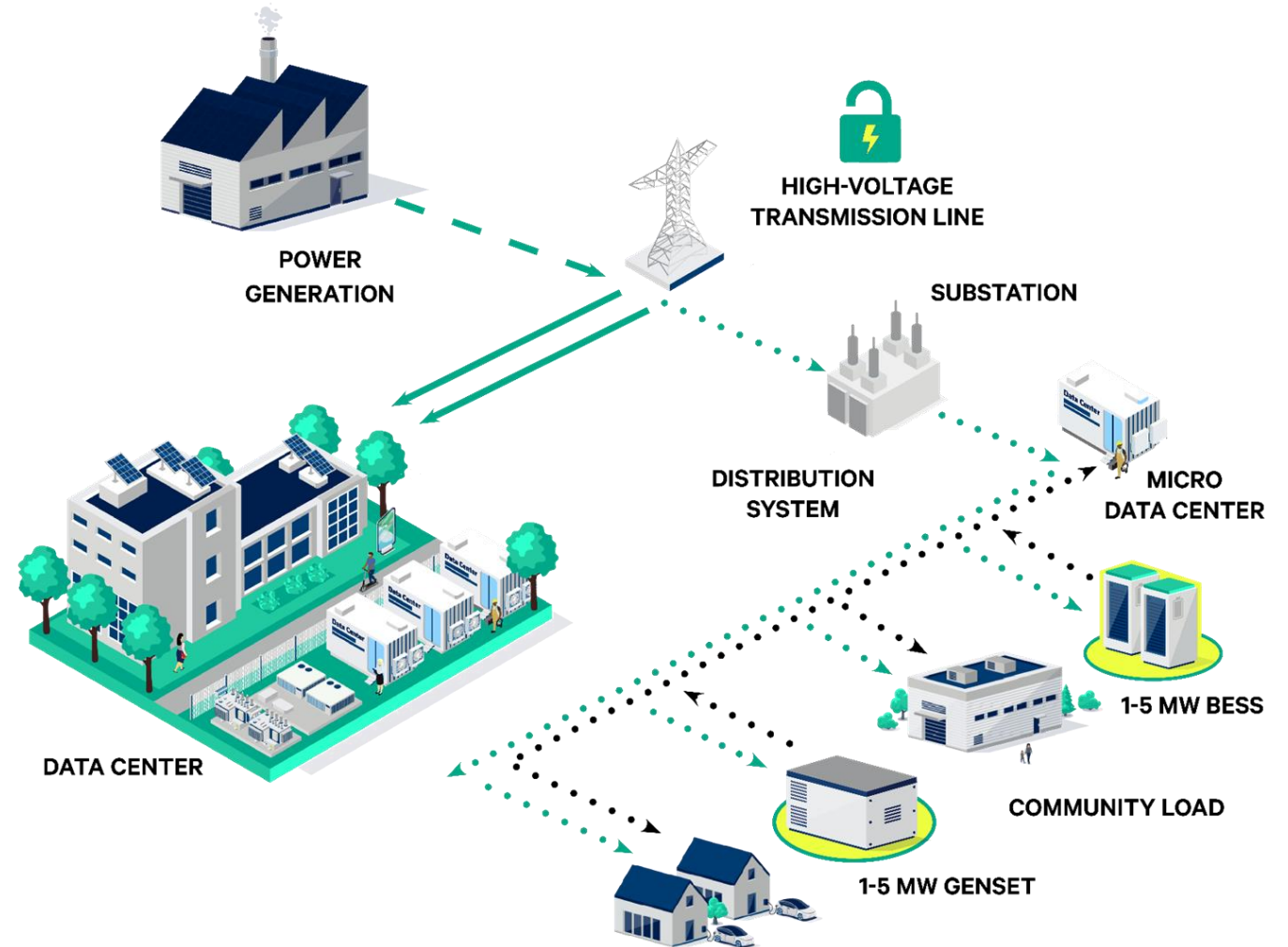

# Why is Distributed Capacity Valuable?

# Three Ways to Improve System Utilization

System utilization is improved by adding new load when and where there is spare capacity. System headroom can be created through flexibility, efficiency, and other cost-effective capacity solutions.

**1** Add new load in **locations** where sufficient headroom already exists on the system.

**2** Add new load at **times** when there is spare capacity. This is possible if the new customers are flexible and/or can self-supply during peak conditions.

**3** Incentivize technologies and behavioral changes that reduce peak demand of existing load. This creates new headroom on the system, which can then accommodate the addition of new load.

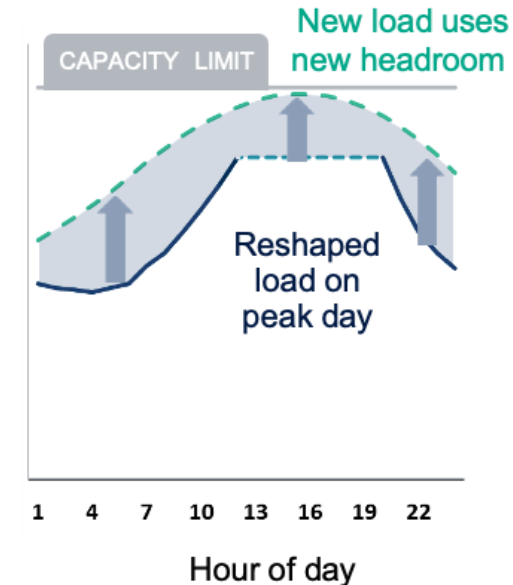
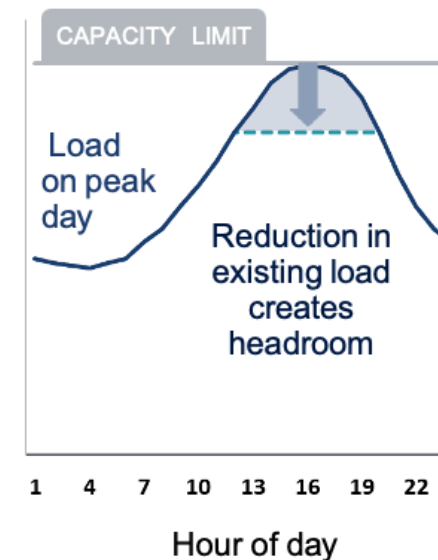
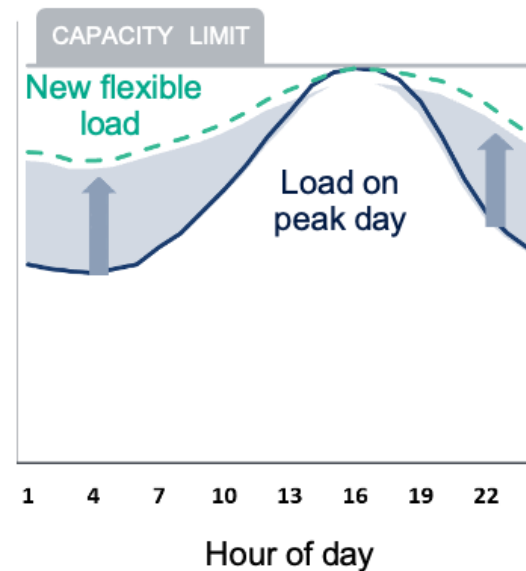
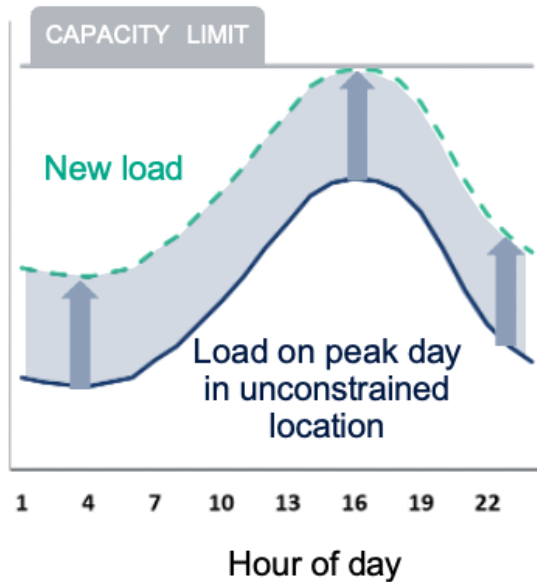

# Impact of Improved System Utilization

## Status Quo

With load growth but no system utilization improvement, the cost of serving new customers exceeds the revenue that is collected from them. Rates increase for all customers by 1.4% to make up for the shortfall (all else equal).

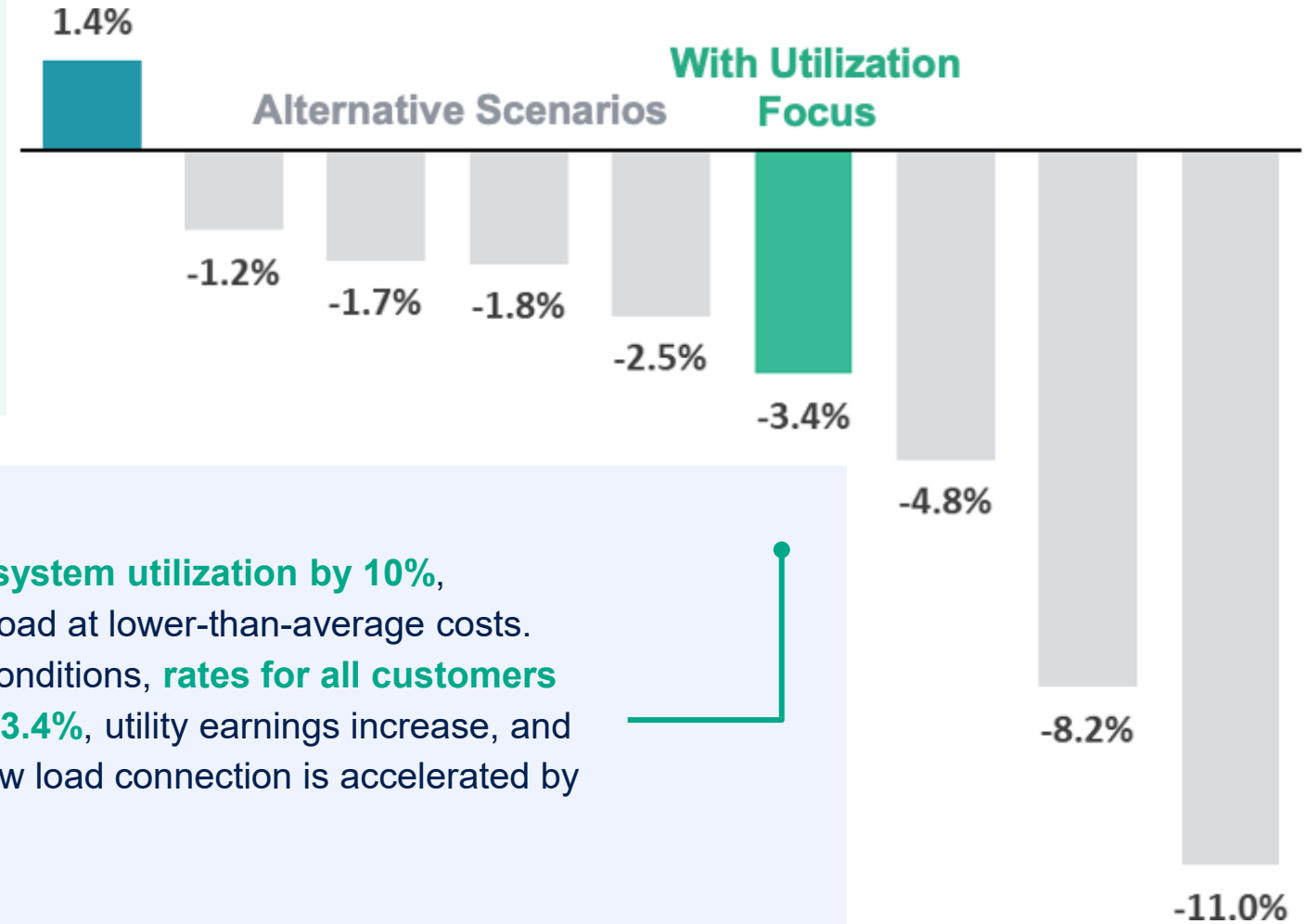

**Increasing annual system utilization by 10%**, integrates the new load at lower-than-average costs. Relative to current conditions, **rates for all customers can be reduced by 3.4%**, utility earnings increase, and connection of the new load connection is accelerated by several years.

# The 1-5 Megawatt Sweet Spot

How front-of-the-meter distributed assets can unlock grid capacity fast.

When deployed at scale as distribution infrastructure, 1-5 MW FTM batteries and gensets can:

- ✓ Help meet load growth
- ✓ Support reliability
- ✓ Avoid overspending and overbuilding
- ✓ Increase system utilization
- ✓ Put downward pressure on rates

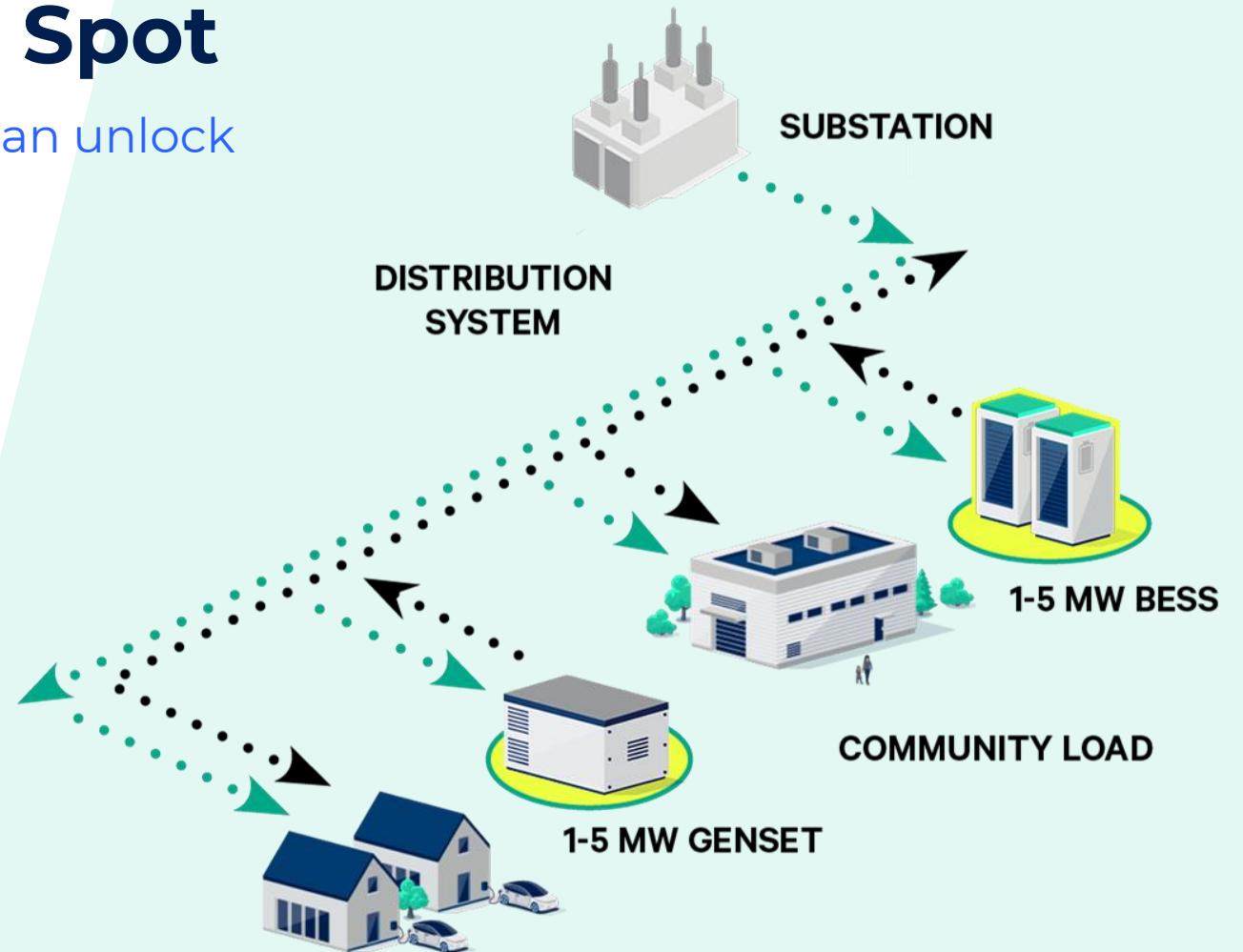

# Why FTM Distributed 1-5 MW Assets?



## MEETS THE MOMENT

Fast, cost-effective capacity to meet rising demand and strengthen resource adequacy.



## RIGHT SIZED

FTM distribution resource for the infrastructure layer that matches the peak capacity of feeders.



## UTILITY-GRADE POWER

Large enough to be dispatchable system assets via SCADA connection and secure telemetry.



## UNIQUE GRID SERVICES

Local congestion relief, voltage support, upgrade deferral, and peak shaving.



## COMPLETES THE PORTFOLIO

Fills the gap between utility-scale generation and demand response.

## In order to deliver real system value, distributed capacity must:



**Be a part of core system planning**



**Be confidently deployed at meaningful scale**



**Be verifiable and dispatchable**

# Distributed Capacity is on the List of Grid Growth

## TODAY

The existing system (even with delayed retirements) is struggling to keep up with demand.

Builds the Fast-Growing Grid

Natural Gas Generation

Utility-Scale Renewables

Nuclear, Geothermal & Other Clean Firm

Builds the Fast-Growing Grid

NEW TRANSMISSION

Distributed Capacity

## TOMORROW

An abundant, reliable & affordable grid powers economic growth.